

VC-R32 RS-232 Command Set

No	Issue Date	Description	Apply Firmware
1	2026/05/20	First version.	VVU104

***Notice:**



1. The RS-232 command list is for VC-R32.
2. The yellow highlight  means the latest update.
3. The blue highlight  means the deleted item.

Table of Contents

Versions and Reversions	P1
RS-232 Command List	P10
Visca over IP	P29

1. Communication Protocol

Transmit Method: Asynchronous Interface Half Duplex Serial Communication

- Transmit Speed: 9600bps or 38400bps
- Start bit: 1Bit
- Parity Check: NA
- Data Bit: 8Bit
- Stop Bit: 1Bit

2. The wire diagram

The RS-232 in wire diagram between presenter and remote controller as below.

RJ45	IN	OUT	RS232
1	NA	NA	
2	NA	NA	
3	GND	GND	GND
4	TX	RX	RS232
5	RX	TX	RS232
6	DTR	DSR	RS232
7	NA	NA	
8	NA	NA	

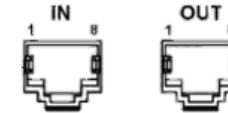

RS-232 out to in (daisy chain) only need normal Cat5e Ethernet cable.

1 ACK & Completion message

	Reply Packet	Note
Ack	X0 4Y FF	Y = socket number
Completion (commands)	X0 5Y FF	Y = socket number
Completion (Inquiries)	X0 50 ... FF	
X = 9 to F==>camera address + 8 , Y=1 to 2		

2 Error message

Error Packet	Description
X0 60 02 FF	Syntax Error
X0 60 03 FF	Command buffer full
X0 6Y 04 FF	Command cancelled
X0 6Y 05 FF	No socket (to be cancelled)
X0 6Y 41 FF	Command not executable
X = 9 to F==>camera address + 8, Y = socket number, Y=0 to 2, 0: Inquiry not execution	

3 Command execution cancel

	Cancel Packet	Note
Cancel	8X 2Y FF	Y = socket number
X = 1 to 7==>camera address, Y = socket number, Y=1 to 2		

4 Network Change

	Packet	Note
Address	88 30 01 FF	Always broadcasted (Reply:88 30 0w FF w:1+Address)
Network Change	X0 38 FF	
X = 9 to F==>camera address + 8		

5 IF_Clear

	Command	Reply Packet Note
IF_Clear	8X 01 00 01 FF	X0 50 FF
IF_Clear (broadcast)	88 01 00 01 FF	88 01 00 01 FF
X = 1 to 7==>camera address (For inquiry packet)		
X = 9 to F==>camera address +8 (For reply packet)		

6 Zoom Focus Position Table

Zoom Position	Wide end	Tele end
	0000	to 4000
Focus Position	Far end	Near end
	000	to 3A4
Focus Near Limit	NA	

7 AE_Shutter Table

	Index(pq)	60/30 mode	50/25 mode
Shutter Speed	00	-	-
	01	-	-
	02	-	-
	03	-	-
	04	-	-
	05	1/30	1/25
	06	1/60	1/50
	07	1/90	1/75
	08	1/100	1/100
	09	1/120	1/120
	0A	1/180	1/150
	0B	1/250	1/215
	0C	1/350	1/300
	0D	1/500	1/425
	0E	1/725	1/600
	0F	1/1000	1/1000
	10	1/1500	1/1250
	11	1/2000	1/1750
	12	1/2500	1/2500
	13	1/3000	1/3000
	14	1/5000	1/5000
	15	1/10000	1/10000

8 AE_Gain Table

Gain	Index(pq)	Value
	0F	+45 dB
	0E	+42 dB
	0D	+39 dB
	0C	+36 dB
	0B	+33 dB
	0A	+30 dB
	09	+27 dB
	08	+24 dB
	07	+21 dB
	06	+18 dB
	05	+15 dB
	04	+12 dB
	03	+9 dB
	02	+6 dB
	01	+3 dB
00	0 dB	

9 AE_Gain limit Table

Gain limit	Index(pq)	Value
	0F	+45 dB
	0E	+42 dB
	0D	+39 dB
	0C	+36 dB
	0B	+33 dB
	0A	+30 dB
	09	+27 dB
	08	+24 dB
	07	+21 dB
	06	+18 dB
	05	+15 dB
	04	+12 dB
	03	+9 dB

10 AE_Exposure Comp. Table

Exposure Comp. (AE Level)	Index(pq)	Value(Level)	(Gain)Value
	0A	5	+8.0 dB
	09	4	+6.4 dB
	08	3	+4.8 dB
	07	2	+3.2 dB
	06	1	+1.6 dB
	05	0	0 dB
	04	-1	-1.6 dB
	03	-2	-3.2 dB
	02	-3	-4.8 dB
	01	-4	-6.4 dB
00	-5	-8.0 dB	

11 AE_Iris Table

IRIS F1.6~14	Index(pq)	F Number
	0F	F 1.6
	0E	F 2.0
	0D	F 2.2
	0C	F 2.7
	0B	F 3.2
	0A	F 3.8
	09	F 4.5
	08	F 5.4
	07	F 6.3
	06	-
	05	-
	04	-
	03	-
	02	-
01	-	
00	-	

12 RS232 Command List

Command set	Command	Command packet	Comments
Audio	Audio Enable	8x 01 04 68 0p FF	p: 2=On, 3=Off
	Delay Time	8x 01 04 6A 0p 0q 0r FF	Set AudioDelay Time for Internet Streaming pqr : delay time, range: 001 ~ 1F4 (1 ~ 500)
	Audio In	8x 01 04 6B 0p FF	p: 2=Line In
	Audio Volume	8x 01 04 6E 0p FF	p: 0 ~ A (0 ~ 10)
	Delay Enable	8x 01 04 6F 0p FF	Set AudioDelay On/Off for Internet Streaming p: 2=On, 3=Off
	UAC Enable	8x 01 04 70 0p FF	p: 2=On, 3=Off
Auto Focus	Zoom Tracking	8x 01 04 38 03 0p FF	p: 2=Curve Tracking 3=Zoom Tracking
	PTZ Assist	8x 01 04 38 04 pp FF	pp: 2=On, 3=Off, 10=Toggle
	AF Sensitivity	8x 01 04 58 0p FF	p: 1=High, 2=Middle, 3=Low
	AF Frame	8x 01 04 5C pp FF	p: 1=Auto, 2=Full Frame, 3=Center
	Preset AF	8x 01 04 5E 0p FF	p: 2=On, 3=Off
	Smart AF	8x 01 7E 01 01 0p FF	p: 2=On, 3=Off

Dig-Effect	Mirror	8x 01 04 61 0p FF	p: 2=On, 3=Off
	Flip	8x 01 04 66 0p FF	p: 2=On, 3=Off
Ethernet	DHCP	8x 01 7C 01 0p FF	p: 2=On, 3=Off
	IP Address	8x 01 7C 02 0p 0q 0r 0s 0t 0u 0v 0x FF	address : pq.rs.tu.vx (HEX), pq = 0~255, rs = 0~255, tu = 0~255, vx = 0~255, e.g. 192.168.100.150 => 81 01 7C 02 0C 00 0A 08 06 04 09 06 FF
	Subnet Mask	8x 01 7C 03 0p 0q 0r 0s 0t 0u 0v 0x FF	address : pq.rs.tu.vx (HEX), pq = 0~255, rs = 0~255, tu = 0~255, vx = 0~255, e.g. 255.255.255.0 => 81 01 7C 03 0F 0F 0F 0F 0F 0F 00 00 FF
	Gateway	8x 01 7C 04 0p 0q 0r 0s 0t 0u 0v 0x FF	address : pq.rs.tu.vx (HEX), pq = 0~255, rs = 0~255, tu = 0~255, vx = 0~255, e.g. 192.168.100.254 => 81 01 7C 04 0C 00 0A 08 06 04 0F 0E FF
	DNS	8x 01 7C 05 0p 0q 0r 0s 0t 0u 0v 0x FF	address : pq.rs.tu.vx (HEX), pq = 0~255, rs = 0~255, tu = 0~255, vx = 0~255, e.g. 8.8.8.8 => 81 01 7C 05 00 08 00 08 00 08 00 08 FF
Exposure			Reset Shutter Setting to the default value depending on the frame rate of Output Mode (* Available during Shutter Priority/Manual Mode)
	Shutter Reset	8x 01 04 0A 00 FF	
	Shutter Up	8x 01 04 0A 02 FF	Shutter Setting (* Available during Shutter Priority/Manual Mode)
	Shutter Down	8x 01 04 0A 03 FF	Shutter Setting (* Available during Shutter Priority/Manual Mode)
	Iris Reset	8x 01 04 0B 00 FF	Available during Iris Priority/Manual Mode

Exposure	Iris Up	8x 01 04 0B 02 FF	Iris Up (* Available +E25:E44during Iris Priority/Manual Mode)
	Iris Down	8x 01 04 0B 03 FF	Iris Down (* Available during Iris Priority/Manual Mode)
	Manual Gain Reset	8x 01 04 0C 00 FF	Reset Gain Setting to 0 (0 dB) value (* Available during AE Manual Mode)
	Manual Gain Up	8x 01 04 0C 02 FF	Gain Setting (* Available during AE Manual Mode)
	Manual Gain Down	8x 01 04 0C 03 FF	Gain Setting (* Available during AE Manual Mode)
	Exposure Comp Reset	8x 01 04 0E 00 FF	Reset Exposure Compensation to 5 value (* Available during ExpComp On)
	Exposure Comp Up	8x 01 04 0E 02 FF	Exposure Compensation Up (* Available during ExpComp On)
	Exposure Comp Down	8x 01 04 0E 03 FF	Exposure Compensation Down (* Available during ExpComp On)
	Spot Light Position	8x 01 04 29 0p 0q 0r 0s FF	pq: X-axis, 00 ~ 06 rs: Y-axis, 00 ~ 04
	Iris Limit (Max)	8x 01 04 2A 0p FF	"p: Iris F number, parameters are in the General Table (* Disabled during AE Manual Mode and IrisPri Mode)"
	Gain Limit	8x 01 04 2C 0p FF	p: parameters are in the General Table
	WDR	8x 01 04 2D 0p FF	p: WDR mode, 0 ~ 3
	Back Light	8x 01 04 33 0p FF	Back Light Compensation ON/OFF p: 2=On, 3=Off (* Available during Full Auto Mode)

Exposure	Mode	8x 01 04 39 0p FF	p: 0=Full Auto, 3=Manual, A=Shutter Priority, B=Iris Priority
	Exposure Comp On/Off	8x 01 04 3E 0p FF	p: 2=On, 3=Off (* Disabled during Manual Mode)
	Shutter Direct	8x 01 04 4A 00 00 0p 0q FF	pq: Shutter Position, parameters are in the General Table (* Available during Shutter Priority/Manual Mode)
	Iris Direct	8x 01 04 4B 00 00 0p 0q FF	pq: Iris Position, parameters are in the General Table (* Available during Iris Priority/Manual Mode)
	Manual Gain Direct	8x 01 04 4C 00 00 0p 0q FF	pq: Gain Position, parameters are in the General Table
	Exposure Comp Direct	8x 01 04 4E 00 00 0p 0q FF	pq: 00 ~ 0A
	Spot Light	8x 01 04 59 0p FF	p: 2=On, 3=Off
Focus	Stop	8x 01 04 08 00 FF	Available during Manual Focus Mode
	Far (Standard Speed)	8x 01 04 08 02 FF	Available during Manual Focus Mode
	Near (Standard Speed)	8x 01 04 08 03 FF	Available during Manual Focus Mode
	Far Step	8x 01 04 08 04 FF	Available during Manual Focus Mode
	Near Step	8x 01 04 08 05 FF	Available during Manual Focus Mode
	Far (Variable Speed)	8x 01 04 08 2p FF	p: Speed 0 (Low) ~ 7 (High) (* Available during Manual Focus Mode)
	Near (Variable Speed)	8x 01 04 08 3p FF	p: Speed 0 (Low) ~ 7 (High) (* Available during Manual Focus Mode)

Focus	One Push Trigger	8x 01 04 18 01 FF	One Push AF Trigger (* Available during Manual Focus Mode)
	Mode	8x 01 04 38 0p FF	p: 2=Auto Focus, 3=Manual Focus
	Direct	8x 01 04 48 0p 0q 0r 0s FF	pqrs: Focus Position , pqrs parameters are in the General Zoom Focus Table (* Available during Manual Focus Mode)
Menu	Left	8x 01 06 01 01 01 01 03 FF	OSD Menu left
	Right	8x 01 06 01 01 01 02 03 FF	OSD Menu right
	Up	8x 01 06 01 01 01 03 01 FF	OSD Menu up
	Down	8x 01 06 01 01 01 03 02 FF	OSD Menu down
	On/Off	8x 01 06 06 pp FF	Turn on/off OSD menu screen pp: 2=On, 3=Off, 10=Toggle
	Enter	8x 01 7E 01 02 00 01 FF	OSD Menu Enter
Pan Tilt	Pan Flip	8x 01 04 67 3F 0p FF	p: 2=On, 3=Off
	Tilt Flip	8x 01 04 68 3F 0p FF	p: 2=On, 3=Off
	Stop	8x 01 06 01 00 00 03 03 FF	
	UpLeft	8x 01 06 01 VV WW 01 01 FF	VV: Pan Speed 0x01 (Low) ~ 0x18 (High) WW: Tilt Speed 0x01 (Low) ~ 0x18 (High)
	DownLeft	8x 01 06 01 VV WW 01 02 FF	VV: Pan Speed 0x01 (Low) ~ 0x18 (High) WW: Tilt Speed 0x01 (Low) ~ 0x18 (High)
	Left	8x 01 06 01 VV WW 01 03 FF	VV: Pan Speed 0x01 (Low) ~ 0x18 (High) WW: Tilt Speed 0x01 (Low) ~ 0x18 (High)

Pan Tilt	UpRight	8x 01 06 01 VV WW 02 01 FF	VV: Pan Speed 0x01 (Low) ~ 0x18 (High) WW: Tilt Speed 0x01 (Low) ~ 0x18 (High)
	DownRight	8x 01 06 01 VV WW 02 02 FF	VV: Pan Speed 0x01 (Low) ~ 0x18 (High) WW: Tilt Speed 0x01 (Low) ~ 0x18 (High)
	Right	8x 01 06 01 VV WW 02 03 FF	VV: Pan Speed 0x01 (Low) ~ 0x18 (High) WW: Tilt Speed 0x01 (Low) ~ 0x18 (High)
	Up	8x 01 06 01 VV WW 03 01 FF	VV: Pan Speed 0x01 (Low) ~ 0x18 (High) WW: Tilt Speed 0x01 (Low) ~ 0x18 (High)
	Down	8x 01 06 01 VV WW 03 02 FF	VV: Pan Speed 0x01 (Low) ~ 0x18 (High) WW: Tilt Speed 0x01 (Low) ~ 0x18 (High)
	Absolute Position	8x 01 06 02 VV WW 0Y 0Y 0Y 0Y 0Z 0Z 0Z 0Z FF	YYYY : Pan Position 0x0000 ~ 0x7AC8 & 0x8538 ~ 0xFFFF (Center 0000) ZZZZ : Tilt Position 0x0000 ~ 0x7D00 & 0xD655 ~ 0xFFFF (Center 0000)
	Relative Position	8x 01 06 03 VV WW 0Y 0Y 0Y 0Y 0Z 0Z 0Z 0Z FF	YYYY : Pan Position 0x0000 ~ 0x7AC8 & 0x8538 ~ 0xFFFF (Center 0000) ZZZZ : Tilt Position 0x0000 ~ 0x7D00 & 0xD655 ~ 0xFFFF (Center 0000)
	Home	8x 01 06 04 FF	Go Home Position
	Reset	8x 01 06 05 FF	Initialize Pan Tilt and go to last position
	Pan Tilt Limit	8x 01 06 07 00 0W 0Y 0Y 0Y 0Y 0Z 0Z 0Z 0Z FF	W: 1=Up & Right YYYY: Pan Limit Position 0x0000~0x6A40 ZZZZ: Tilt Limit Position 0x0000~0x3840 W: 0=Down & Left YYYY: Pan Limit Position 0xFFFF~0x95C0 ZZZZ: Tilt Limit Position 0xFFFF~0xED40

Pan Tilt	Limit Clear	8x 01 06 07 01 0W 07 0F 0F 0F 07 0F 0F 0F FF	W: 1=Clear Up & Right, 0=Clear Down & Left
	PTZ Motion Sync	8x 01 04 38 05 0p FF	p: 2=On, 3=Off
	PTZ Speed Comp	8x 01 06 1F 01 0p FF	p: 0=Off, 1=On
	Preset Speed	8x 01 06 20 0p FF	p: 0=5 deg/sec, 1=25 deg/sec, 2=50 deg/sec, 3=80 deg/sec, 4=120 deg/sec, 5=160 deg/sec, 6=200 deg/sec, 7=300 deg/sec
Pan Tilt Zoom	ZOOM OUT FIRST EN	8x 01 7E 11 00 0q FF	p:02=ON, 03=OFF
	ZOOM OUT FIRST PRESET1	8x 01 7E 11 01 0q FF	p:02=ON, 03=OFF
	ZOOM OUT FIRST PRESET2	8x 01 7E 11 02 0q FF	p:02=ON, 03=OFF
Picture	Sharpness Reset	8x 01 04 02 00 FF	
	Sharpness Up	8x 01 04 02 02 FF	Sharpness Up
	Sharpness Down	8x 01 04 02 03 FF	Sharpness Down
	Brightness Reset	8x 01 04 0D 00 FF	
	Brightness Up	8x 01 04 0D 02 FF	Brightness Up
	Brightness Down	8x 01 04 0D 03 FF	Brightness Down
	Image Mode	8x 01 04 3F 04 0p FF	p: 0=Standard, 3=Brilliant

Picture	Advanced	8x 01 04 3F 07 0p FF	p: 2=On, 3=Off
	Sharpness Direct	8x 01 04 42 00 00 0p 0q FF	pq: 00 ~ 0E
	Saturation	8x 01 04 49 00 00 0p 0q FF	pq: 00 ~ 0F (* Available during Image Mode = Custom mode)
	Brightness Direct	8x 01 04 4D 00 00 0p 0q FF	pq: 00 ~ 0F (* Available during Image Mode = Custom mode)
	Hue	8x 01 04 4F 00 00 0p 0q FF	pq: 00 ~ 0F (* Available during Image Mode = Custom mode)
	2D NR	8x 01 04 53 0p FF	p: 0=Off, 1=Level 1, 2=Level 2, 3=Level 3
	3D NR	8x 01 04 54 0p FF	p: 0=Off, 1=Low, 2=Type, 3=Max
	Gamma	8x 01 04 5B 0p FF	p: 0 ~ 3 (* Available during Image Mode = Custom mode)
	Freeze	8x 01 04 62 0p FF	p: 2=On, 3=Off
	Picture Effect	8x 01 04 63 0p FF	p: 0=Off, 4=B&W
Power	On/Standby	8x 01 04 00 0p FF	p: 2=On, 3=Standby
	Standby Mode	8x 01 7E 01 0A 03 0p FF	p: 2=Normal Standby (Lens Tilt Down), 3=Ceiling Standby (Lens Tilt Up)

Preset	Reset	8x 01 04 3F 00 pp FF	pp: Memory Number 0x00 ~ 0x7F (* Preset address range : 0 ~ 127)
	Set	8x 01 04 3F 01 pp FF	pp: Memory Number 0x00 ~ 0x7F (* Preset address range : 0 ~ 127)
	Recall	8x 01 04 3F 02 pp FF	pp: Memory Number 0x00 ~ 0x7F (* Preset address range : 0 ~ 127)
	Reset	8x 01 04 3F 10 pp FF	pp: Memory Number 0x00 ~ 0x7F (* Preset address range: 128 ~ 255)
	Set	8x 01 04 3F 11 pp FF	pp: Memory Number 0x00 ~ 0x7F (* Preset address range: 128 ~ 255)
	Recall	8x 01 04 3F 12 pp FF	pp: Memory Number 0x00 ~ 0x7F (* Preset address range: 128 ~ 255)
System	PrivacyMode	8x 01 04 00 02 0p FF	p: 2=On, 3=Off
	Prompt	8x 01 04 07 00 0p FF	p: 2=On, 3=Off
	Baud Rate	8x 01 04 24 00 00 0p FF	p: 0=9600 bps, 1=38400 bps
	Factory Reset (Soft)	8x 01 04 3F 03 00 FF	Reset camera setting
	Factory Reset (Hard)	8x 01 04 3F 03 01 FF	Reset camera and network setting
	Control Port	8x 01 04 53 45 52 49 41 4C 0p FF	p: 2=RS422, 3=RS232
	Initial Position	8x 01 04 75 6A 0p FF	p: 0=Last MEM, 1=1st Preset
	IR Receive	8x 01 06 08 pp FF	pp: 2=On, 3=Off
	IR ID	8x 01 06 0A 0q FF	q: 1=ID1, 2=ID2, 4=ID3
	FreeD Enable	8x 01 06 1F 10 0p FF	p: 2=On, 3=Off
	Output Mode	8x 01 06 35 0p 0q FF	pq: 07=FHD 1080P(1920 x 1080) - 60p
	Output Mode	8x 01 06 35 0p 0q FF	pq: 09=FHD 1080P(1920 x 1080) - 50p

System	Output Mode	8x 01 06 35 0p 0q FF	pq: 0A=FHD 1080P(1920 x 1080) - 30p
	Output Mode	8x 01 06 35 0p 0q FF	pq: 0C=FHD 1080P(1920 x 1080) - 25p
	Output Mode	8x 01 06 35 0p 0q FF	pq: 0D=HD 720P(1280 x 720) - 60p
	Output Mode	8x 01 06 35 0p 0q FF	pq: 0F=HD 720P(1280 x 720) - 50p
	HDMI Format	8x 01 06 36 0p FF	p: 0=RGB, 2=YUV422
	Motionless Preset	8x 01 07 01 0p FF	p: 2=On, 3=Off
	Lamp	8x 01 7E 01 0A 00 0p FF	p: 2=Enable, 3=Disable
	Mode	8x 01 7E 01 0A 01 0p FF	p: 0=Red-Off / Green-Off, 4=Red-On (Low) / Green-Off, 5=Red-On (High) / Green-Off, 6=Red-Off / Green-On, 7=Red-On (High) / Green-On, (* Tally Lamp must be Enabled for non-zero value)
	CMMD Mode	8x 01 7E 01 0A 04 0p FF	p: 2=Link, 3=Normal
	Teams Mode On/Off	8x 01 7E 02 06 0p FF	
	Write Camera ID	8x 01 CE aa bb cc dd ee ff gg hh ii jj kk ll FF	aa bb cc dd ee ff gg hh ii jj kk ll : Camera ID (ASCII)
Reboot	8x 01 DE 01 FF	Set to reboot	
Tracking	Sensitivity	8x 01 0B 00 02 0p FF	p: 0= Low, 1=Middle, 2=High
	Auto Framing_Correction	8x 01 0B 04 00 00 FF	
	Auto Framing On/Off	8x 01 0B 04 02 0p FF	p: 2=On, 3=Off
White Balance	Manual Red Reset	8x 01 04 03 00 FF	Reset R Gain Setting to 40 (64) value (* Available during WB Manual mode)
	Manual Red Up	8x 01 04 03 02 FF	R Gain Up (* Available during WB Manual mode)
	Manual Red Down	8x 01 04 03 03 FF	R Gain Down (* Available during WB Manual mode)

White Balance	Manual Blue Reset	8x 01 04 04 00 FF	Reset B Gain Setting to 40 (64) value (* Available during WB Manual mode)
	Manual Blue Up	8x 01 04 04 02 FF	B Gain Up (* Available during WB Manual mode)
	Manual Blue Down	8x 01 04 04 03 FF	B Gain Down (* Available during WB Manual mode)
	One Push Trigger	8x 01 04 10 05 FF	One Push WB Trigger (* Available during One Push WB Mode)
			p: 0=Auto, 1=Indoor, 2=Outdoor, 3=One Push WB, 4=ATW, 5=Manual, 6=Sodium Lamp, 7=3000K, 8=4300K, 9=5000K, A=6500K, B=8000K
	Mode	8x 01 04 35 0p FF	
	Manual Red Direct	8x 01 04 43 00 00 0p 0q FF	pq: 00 ~ 80 (0 ~ 128)
	Manual Blue Direct	8x 01 04 44 00 00 0p 0q FF	pq: 00 ~ 80 (0 ~ 128)
Zoom	Stop	8x 01 04 07 00 FF	
	Tele (Standard Speed)	8x 01 04 07 02 FF	
	Wide (Standard Speed)	8x 01 04 07 03 FF	
	Tele Step	8x 01 04 07 04 FF	

Zoom	Wide Step	8x 01 04 07 05 FF	
	Tele (Variable Speed)	8x 01 04 07 2p FF	p=0 (Low) ~ 7 (High)
	Wide (Variable Speed)	8x 01 04 07 3p FF	p=0 (Low) ~ 7 (High)
	Digital Zoom Limit	8x 01 04 26 0p FF	p: 0 (x1) ~ B (x12)
	Direct (Variable Speed)	8x 01 04 47 0p 0q 0r 0s 0t FF	pqrs: Zoom Position, Min. 0000h Max. 4000h (In D-Zoom Limit = x1) Max. 7AC0h (In D-Zoom Limit = x2 ~ 12x) t: Zoom Speed, 0 (Low) ~ 7 (High)
	Direct (Standard Speed)	8x 01 04 47 0p 0q 0r 0s FF	pqrs: Zoom Position, Min. 0000h Max. 4000h (In D-Zoom Limit = x1) Max. 7AC0h (In D-Zoom Limit = x2 ~ 12x)
	Preset Zoom Time Priority	8x 01 7E 11 03 0q FF	p: 2=On, 3=Off
Zoom Focus	Direct (Variable Speed)	8x 01 04 47 0p 0q 0r 0s 0t 0u 0v 0w 0x FF	pqrs: Zoom Position, 0x0000 ~ 0x4000 tuvw: Focus Position, 0x0000 ~ FocusMaxValue x: Speed, 0 ~ 7 (* Available during Manual Focus Mode)
	Direct (Standard Speed)	8x 01 04 47 0p 0q 0r 0s 0t 0u 0v 0w FF	pqrs: Zoom Position, 0x0000 ~ 0x4000 tuvw: Focus Position, 0x0000 ~ FocusMaxValue (* Available during Manual Focus Mode)

13 RS232 Inquiry Command List

Inquiry Command	Command Packet	Inquiry Packet	Comments
Audio Enable Inq	8x 09 04 68 FF	y0 50 0p FF	p: 2=On, 3=Off
Delay Time Inq	8x 09 04 6A FF	y0 50 0p 0q 0r FF	pqr : delay time, range: 001 ~ 1F4 (1 ~ 500)
Audio In Inq	8x 09 04 6B FF	y0 50 0p FF	p: 2=Line In, 3=Mic In
Encode Sample Rate Inq	8x 09 04 6D FF	y0 50 0p FF	p: 0=48 KHz (AAC)
Audio Volume Inq	8x 09 04 6E FF	y0 50 0p FF	p: 0 ~ A (0 ~ 10)
Delay Enable Inq	8x 09 04 6F FF	y0 50 0p FF	p: 2=On, 3=Off
UAC Enable Inq	8x 09 04 70 FF	y0 50 0p FF	p: 2=On, 3=Off
Zoom Tracking Inq	8x 09 04 38 03 FF	y0 50 0p FF	p: 2=Curve Tracking 3=Zoom Tracking
PTZ Assist Inq	8x 09 04 38 04 FF	y0 50 0p FF	p: 2=On, 3=Off
AF Sensitivity Inq	8x 09 04 58 FF	y0 50 0p FF	p: 1=High, 2=Middle, 3=Low
AF Frame Inq	8x 09 04 5C FF	y0 50 0p FF	p: 1=Auto, 2=Full Frame, 3=Center
Preset AF Inq	8x 09 04 5E FF	y0 50 0p FF	p: 2=On, 3=Off

Smart AF Inq	8x 09 7E 01 01 FF	y0 50 0p FF	p: 2=On, 3=Off
Mirror Inq	8x 09 04 61 FF	y0 50 0p FF	p: 2=On, 3=Off
Flip Inq	8x 09 04 66 FF	y0 50 0p FF	p: 2=On, 3=Off
MAC Address Inq	8x 09 04 78 FF	y0 50 0a 0b 0c 0d 0e 0f 0g 0h 0i 0j 0k 0l FF	MAC Address = ab: cd: ef: gh: ij: kl
DHCP Inq	8x 09 7C 01 FF	y0 50 0p FF	p: 2=On, 3=Off
IP Address Inq	8x 09 7C 02 FF	y0 50 0p 0q 0r 0s 0t 0u 0v 0x FF	address : pq.rs.tu.vx (HEX)
Subnet Mask Inq	8x 09 7C 03 FF	y0 50 0p 0q 0r 0s 0t 0u 0v 0x FF	address : pq.rs.tu.vx (HEX)
Gateway Inq	8x 09 7C 04 FF	y0 50 0p 0q 0r 0s 0t 0u 0v 0x FF	address : pq.rs.tu.vx (HEX)
DNS Inq	8x 09 7C 05 FF	y0 50 0p 0q 0r 0s 0t 0u 0v 0x FF	address : pq.rs.tu.vx (HEX)
Iris Limit Inq (Max)	8x 09 04 2A FF	y0 50 0p FF	p: Iris Limit, parameters are in the General Table
Gain Limit Inq	8x 09 04 2C FF	y0 50 0p FF	p: parameters are in the General Table
WDR Inq	8x 09 04 2D FF	y0 50 0p FF	p: WDR mode, 00 ~ 03
Back Light Inq	8x 09 04 33 FF	y0 50 0p FF	p: 2=On, 3=Off
Mode Inq	8x 09 04 39 FF	y0 50 0p FF	p: 0=Full Auto, 3=Manual, A=Shutter Priority, B=Iris Priority
Exposure Comp Inq	8x 09 04 3E FF	y0 50 0p FF	p: 2=On, 3=Off
Shutter Inq	8x 09 04 4A FF	y0 50 00 00 0p 0q FF	pq: Shutter Position, parameters are in the General Table
Iris Inq	8x 09 04 4B FF	y0 50 00 00 0p 0q FF	pq: Iris Position, parameters are in the General Table
Manual Gain Inq	8x 09 04 4C FF	y0 50 00 00 0p 0q FF	pq: Gain Position, parameters are in the General Table
Exposure Comp Level Inq	8x 09 04 4E FF	y0 50 00 00 0p 0q FF	pq: 00 ~ 0A
Spot Light Inq	8x 09 04 59 FF	y0 50 0p FF	p: 2=On, 3=Off

Mode Inq	8x 09 04 38 FF	y0 50 0p FF	p: 2=Auto Focus, 3=Manual Focus
Position Inq	8x 09 04 48 FF	y0 50 0p 0q 0r 0s FF	pqrs: Focus Position, parameters are in the General Zoom Focus Table near end to far end
Menu Mode Inq	8x 09 06 06 FF	y0 50 0p FF	p: 2=On, 3=Off
Pan Flip Inq	8x 09 04 67 3F FF	y0 50 0p FF	p: 2=On, 3=Off
Tilt Flip Inq	8x 09 04 68 3F FF	y0 50 0p FF	p: 2=On, 3=Off
PanTilt Preset Speed Inq	8x 09 04 75 32 FF	y0 50 0p FF	p: 0=5 deg/sec, 1=25 deg/sec, 2=50 deg/sec, 3=80 deg/sec, 4=120 deg/sec, 5=160 deg/sec, 6=200 deg/sec, 7=300 deg/sec
Position Inq	8x 09 06 12 FF	y0 50 0w 0w 0w 0w 0z 0z 0z 0z FF	www: Pan Position 0000 ~ 0x7AC8 & 0x8538 ~ FFFF (center 0000) zzz: Tilt Position 0000 ~ 0x7D00 & 0xD655 ~ FFFF (center 0000)
PTZ Motion Sync Inq	8x 09 04 38 05 FF	y0 50 0p FF	p: 2=On, 3=Off
PTZ Speed Comp Inq	8x 09 06 1F 01 FF	y0 50 0p FF	p: 0=Off, 1=On
ZOOM OUT FIRST EN Inq	8x 09 7E 11 00 FF	y0 50 0p FF	p:02=ON, 03=OFF
ZOOM OUT FIRST PRESET1 Inq	8x 09 7E 11 01 FF	y0 50 0p FF	p:02=ON, 03=OFF
ZOOM OUT FIRST PRESET2 Inq	8x 09 7E 11 02 FF	y0 50 0p FF	p:02=ON, 03=OFF
Image Mode Inq	8x 09 04 3F 04 FF	y0 50 0p FF	p: 0=Standard, 3=Brilliant

Advanced Inq	8x 09 04 3F 07 FF	y0 50 0p FF	p: 2=On, 3=Off
Sharpness Inq	8x 09 04 42 FF	y0 50 00 00 0p 0q FF	pq: 00 ~ 0E
SaturationInq	8x 09 04 49 FF	y0 50 00 00 0p 0q FF	pq: 00 ~ 0F
Brightness Inq	8x 09 04 4D FF	y0 50 00 00 0p 0q FF	pq: 00 ~ 0F
Hue Inq	8x 09 04 4F FF	y0 50 00 00 0p 0q FF	pq: 00 ~ 0F
2D NR Inq	8x 09 04 53 FF	y0 50 0p FF	p: 0=Off, 1=Level 1, 2=Level 2, 3=Level 3
3D NR Inq	8x 09 04 54 FF	y0 50 0p FF	p: 0=Off, 1=Low, 2=Type, 3=Max
Gamma Inq	8x 09 04 5B FF	y0 50 0p FF	Gamma p: 0 ~ 3
Freeze Inq	8x 09 04 62 FF	y0 50 0p FF	p: 2=Freeze On 3=Freeze Off
Picture Effect Inq	8x 09 04 63 FF	y0 50 0p FF	p: 0=Off, 4=B&W
Power Mode Inq	8x 09 04 00 FF	y0 50 0p FF	p: 2=On, 3=Standby
Project Name Inq (Part1)	8x 09 70 00 00 FF	y0 50 ii jj kk ll mm nn oo pp qq rr ss tt FF	ii jj kk ll mm nn oo pp qq rr ss tt : project name (part 1) Project Name = part 1+part 2 (Development Only)

Project Name Inq (Part2)	8x 09 70 00 01 FF	y0 50 ii jj kk ll mm nn oo pp qq rr ss tt FF	ii jj kk ll mm nn oo pp qq rr ss tt : project name (part 2) (Development Only)
FW version Inq - Linux	8x 09 00 02 00 03 FF	y0 50 mm nn oo pp qq rr ss FF	mmnnnooppqrrss : XXXxxxx(Ascii, data range = 0x00 ~ 0x7F)
FW version Inq - Motor	8x 09 00 02 00 04 FF	y0 50 mm nn oo pp qq rr ss FF	mmnnnooppqrrss : XXXxxxx(Ascii, data range = 0x00 ~ 0x7F)
SERIAL INQ	8x 09 02 18 FF	y0 50 aa bb cc dd ee ff gg hh ii FF	aa bb cc dd ee ff gg hh ii : Serial Number (ASCII)
Privacy Mode Inq	8x 09 04 00 02 FF	y0 50 0p FF	p: 2=Privacy Mode On 3=Privacy Mode Off
Prompt Inq	8x 09 04 07 00 FF	y0 50 0p FF	p: 2=On, 3=Off
Baud Rate Inq	8x 09 04 24 00 FF	y0 50 00 0p FF	p: 0=9600 bps, 1=38400 bps
Initial Position Inq	8x 09 04 75 6A FF	y0 50 0p FF	p: 0=Last MEM, 1=1st Preset
IR ID Inq	8x 09 06 0A FF	y0 50 0q FF	q: 1=ID1, 2=ID2, 4=ID3
FreeD Enable Inq	8x 09 06 1F 10 FF	y0 50 0p FF	p: 2=On, 3=Off
Output Mode Inq	8x 09 06 23 FF	y0 50 0p 0q FF	pq: 07=FHD 1080P(1920 x 1080) - 60p
Output Mode Inq	8x 09 06 23 FF	y0 50 0p 0q FF	pq: 09=FHD 1080P(1920 x 1080) - 50p
Output Mode Inq	8x 09 06 23 FF	y0 50 0p 0q FF	pq: 0A=FHD 1080P(1920 x 1080) - 30p
Output Mode Inq	8x 09 06 23 FF	y0 50 0p 0q FF	pq: 0C=FHD 1080P(1920 x 1080) - 25p
Output Mode Inq	8x 09 06 23 FF	y0 50 0p 0q FF	pq: 0D=HD 720P(1280 x 720) - 60p
Output Mode Inq	8x 09 06 23 FF	y0 50 0p 0q FF	pq: 0F=HD 720P(1280 x 720) - 50p
HDMI Format Inq	8x 09 06 36 FF	y0 50 0p FF	p: 0=RGB, 2=YUV422
Motionless Preset Inq	8x 09 07 01 FF	y0 50 0p FF	p: 2=On, 3=Off
Lamp Inq	8x 09 7E 01 0A 00 FF	y0 50 0p FF	p: 2=Enable, 3=Disable

Mode Inq	8x 09 7E 01 0A 01 FF	y0 50 0p FF	p: 0=Red-Off / Green-Off, 4=Red-On (Low) / Green-Off, 5=Red-On (High) / Green-Off, 6=Red-Off / Green-On, 7=Red-On (High) / Green-On
CMMD Mode Inq	8x 09 7E 01 0A 04 FF	y0 50 0p FF	p: 2=Link, 3=Normal
Teams Mode Inq	8x 09 7E 02 06 FF	y0 50 0p FF	p: 2=On, 3=Off
Camera ID Inq	8x 09 7E CE FF	y0 50 aa bb cc dd ee ff gg hh ii jj kk ll FF	aa bb cc dd ee ff gg hh ii jj kk ll : Camera ID (ASCII)
Tracking Sensitivity Inq	8x 09 0B 00 02 FF	y0 50 0p FF	p: 0 : Low 1 : Middle 2 : High
Framing Control Inq	8x 09 0B 04 02 FF	y0 50 0p FF	p: 2=On, 3=Off
Mode Inq	8x 09 04 35 FF	y0 50 0p FF	p: 0=Auto, 1=Indoor, 2=Outdoor, 3=One Push WB, 4=ATW, 5=Manual, 6=Sodium Lamp, 7=3000K, 8=4300K, 9=5000K, A=6500K, B=8000K

Manual Red Inq	8x 09 04 43 FF	y0 50 00 00 0p 0q FF	pq: 00 ~ 80 (0 ~ 128)
Manual Blue Inq	8x 09 04 44 FF	y0 50 00 00 0p 0q FF	pq: 00 ~ 80 (0 ~ 128)
Digital Zoom Limit Inq	8x 09 04 26 FF	y0 50 pq FF	p: 0 (x1) ~ B (x12)
Position Inq	8x 09 04 47 FF	y0 50 0p 0q 0r 0s FF	pqrs: Zoom Position, Min. 0000h Max. 4000h (In D-Zoom Limit = x1) Max. 7AC0h (In D-Zoom Limit = x2 ~ 12x)
Preset Zoom Time Priority Inq	8x 09 7E 11 03 FF	y0 50 0p FF	p: 2=On, 3=Off

14 RS232 over IP

14.1 Overview of RS232 over IP

RS232 over IP allows you to control this unit from the controller with the IP communication function via the LAN by using RS232. You can connect up to 5 controllers simultaneously on one LAN segment.

The communication specifications of RS232 over IP are as follows:

14.2 Interface

RJ-45 10Base-T/100Base-TX (automatically discrimination)

14.3 Internet protocol

IPV4

14.4 Transport protocol

UDP

14.5 IP address

Set by the IP card setting command

14.6 Port address

52381

14.7 Delivery confirmation/Retransmission control

Depends on the application

14.8 Coverage

Limited dedicated network in the same segment without going through a bridge connection.

In this section, the device outputting commands, for example, a computer, is called the controller, and this unit and the devices connected to the same LAN are called the peripheral device. In the connection using RS-232, the controllers and peripheral devices are connected to a one-direction ring. On the IP communication connection, the controllers and peripheral devices are connected by star type through a LAN.

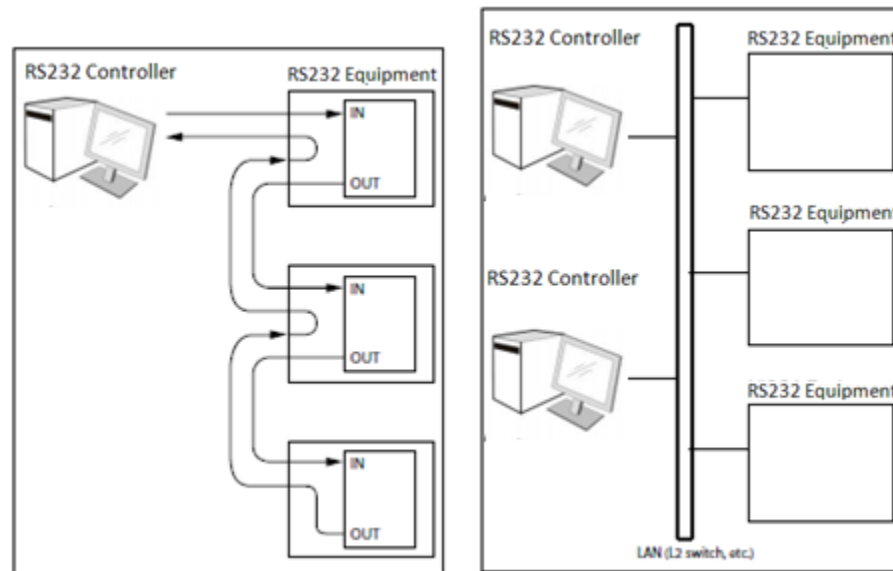

RS232/RS422 connection IP communication connection

While the IP communication connection, the address of each device cannot be set in the RS232 message as it is because the controllers and peripheral devices that are connected simultaneously are increased. In this case, addresses of the controllers and peripheral devices that are set in the RS232 message are locked to 0 (for the controller) or 1 (for the peripheral device).

14.9 Packet Structure

The basic unit of VISCA communication is called a packet [Pic.1]. The first byte of the packet is called the header and comprises the sender's and receiver's addresses. For example, the header of the packet sent to the SRG assigned address 1 from the controller (address 0) is 81h in hexadecimal. The packet sent to the SRG assigned address 2 is 82h. In the command list, as the header is 8X, input the address of the SRG to X. The header of the reply packet from the SRG assigned address 1 is 90h. The packet from the SRG assigned address 2 is A0h.

Some of the setting commands for SRG can be sent to all devices at one time (broadcast)*. In the case of broadcast, the header should be 88h in hexadecimal.

When the terminator is FFh, it signifies the end of the packet.

*The broadcast function is not available for VISCA over IP.

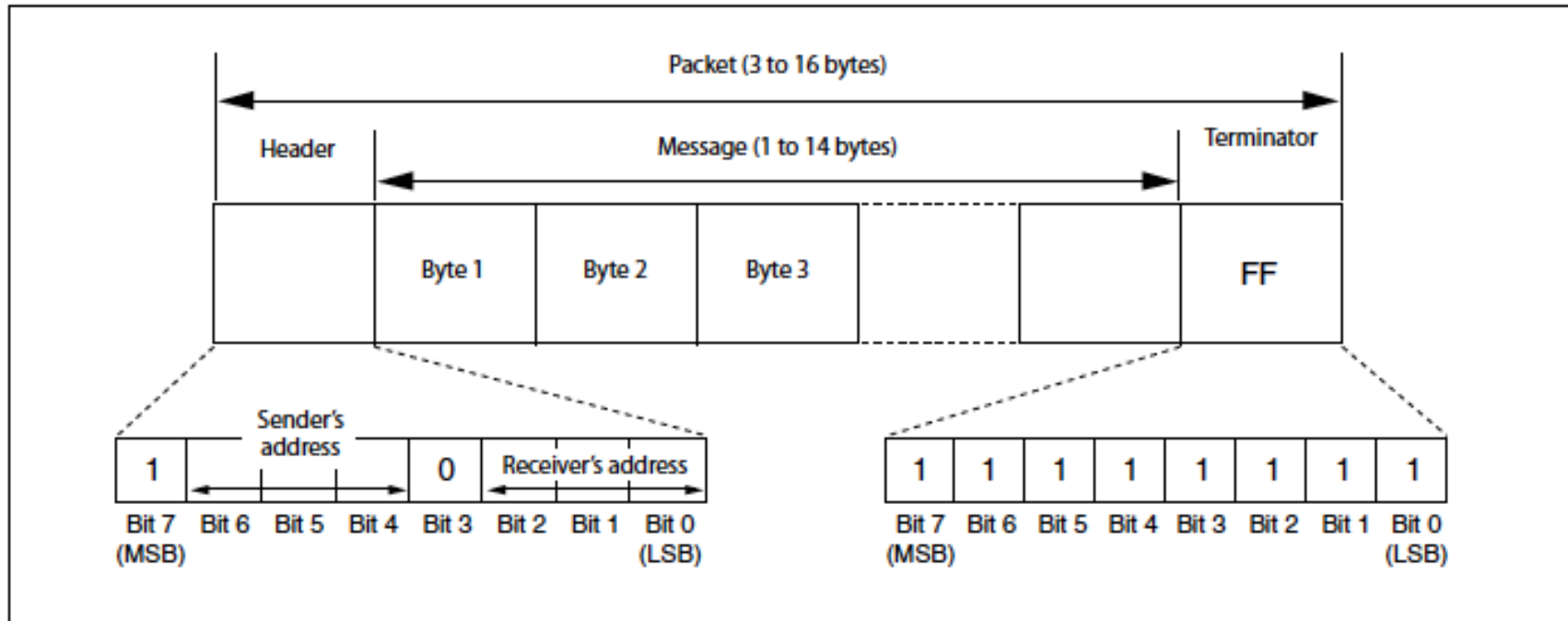

Pic. 1 Packet structure

Note:

Pic. 1 shows the packet structure, while Pic. 2 shows the actual waveform. Data flow will take place with the LSB first.

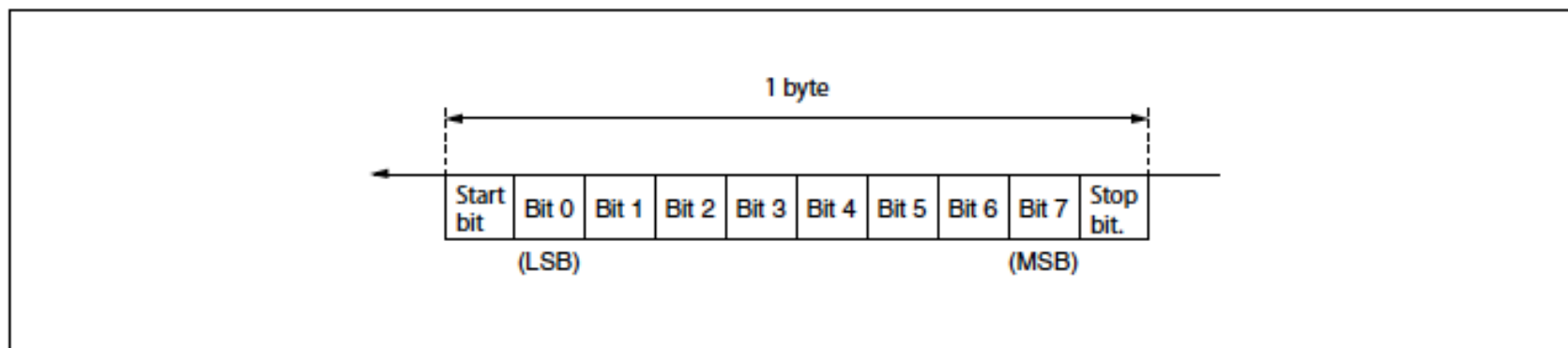

Pic. 2 Actual waveform for 1 byte

15 Communication method of VISCA over IP

15.1 Communication method

VISCA over IP can process the VISCA communication between the controllers and peripheral devices using the messages that can be identified on the LAN, and sends/receives them. Because of this, VISCA over IP is not concerned about the contents of the communication between the controllers and peripheral devices. However, the VISCA communication sequence is different, depending on the types, as follows.

15.2 VISCA command

This is a command from the controller to the peripheral device. When the peripheral device receives this command, Acknowledge is returned. After completing command processing, a completion notice is returned. This command uses the socket of VISCA. The order of completion notices may be changed if the multiple commands are sent to the same peripheral device.

15.3 VISCA inquiry

This is an inquiry from the controller to the peripheral device. When the peripheral device receives this type of command, the reply for the inquiry is returned. This command does not use the socket of VISCA. The order of the replies is not changed if a multiple commands are sent.

15.4 VISCA reply

This is an Acknowledge, completion notice, reply, or error reply from the peripheral device to the controller. The classification for sending messages from the peripheral device to the controller is common.

15.5 VISCA device setting command

This is the device setting command from the controller to the peripheral device. When the peripheral device receives this classifications command, the peripheral device performs the function depend on the command.

15.6 Address

Sets the address of the peripheral device, and does not return a reply to the controller. While using VISCA over IP, the address command is not sent from the controller because a Network Change command from the peripheral device that triggers sending command is not issued.

15.7 IF_Clear

Sends the reply message to the controller after clearing, without using VISCA socket.

15.8 CAM_VerslonInq

Sends the reply message to the controller, without using VISCA socket.

15.9 Format

These are the specifications of the message header (8 bytes) and payload (1 to 16 bytes).

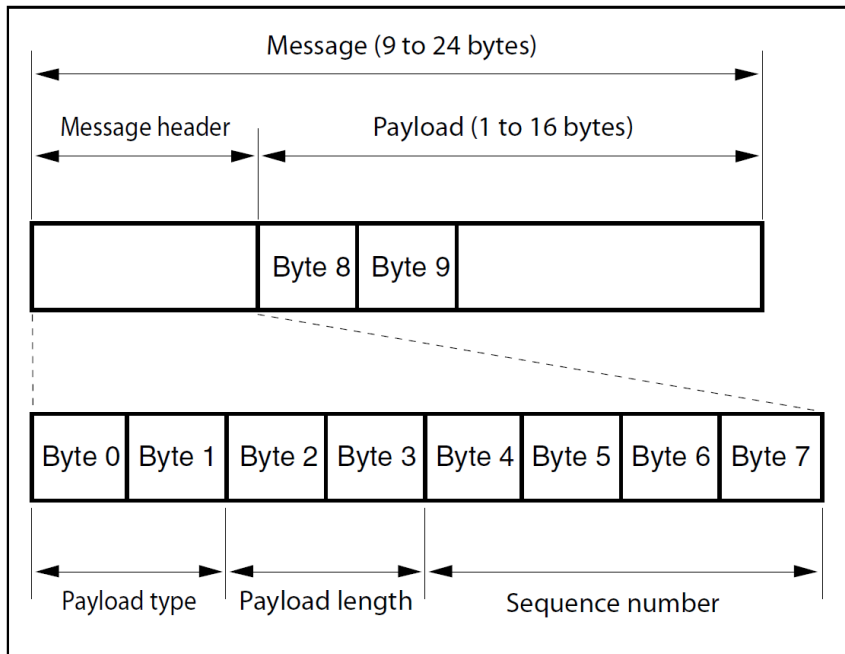

Note: The actual LAN out method is big-endian, LSB first.

Pic.3 Message structure of the VISCA over IP

Example:

Command	Payload type		Payload length		Sequence number				Payload (1~16Byte)										
	Byte 0	Byte 1	Byte 2	Byte 3	Byte 4	Byte 5	Byte 6	Byte 7	Byte 1	Byte 2	Byte 3	Byte 4	Byte 5	Byte 6	Byte 7	Byte 8	Byte 9	...	Byte 16
CAM_Power On	01	00	00	06	00	00	00	01	81	01	04	00	02	FF					
Pan-tiltDrive Up	01	00	00	09	00	00	00	02	81	01	06	01	0C	0C	03	01	FF		
Pan-tiltDrive Down	01	00	00	09	00	00	00	03	81	01	06	01	0C	0C	03	02	FF		
CAM_FocusModelInq	01	10	00	5	00	00	00	04	81	9	4	38	FF						

15.10 Payload type

Stores the value (Byte 0 and Byte 1) of the following table on the payload division.

Name	Value (Byte 0)	Value (Byte 1)	Description
VISCA command	01h	00h	Stores the VISCA command.
VISCA inquiry	01h	10h	Stores the VISCA inquiry.
VISCA reply	01h	11h	Stores the reply for the VISCA command and VISCA inquiry, or VISCA device setting command.
VISCA device setting command	01h	20h	Stores the VISCA device setting command.
Control command	02h	00h	Stores the control command.
Control reply	02h	01h	Stores the reply for the control command.

Pic.4 Payload Type Table

15.11 Payload Length

Stores the number of bytes (1 to 16) of data is stored on the payload.

Example: when the payload length is 16 bytes.

Byte 2:00h

Byte 3:10h

15.12 Sequence number

The controller stores the sequence number that is added every time a message is sent. If the sequence number reaches the limit, next values will be 0. The peripheral device saves the sequence number in the message from the controller, and stores the sequence number of the received message corresponding to the message sent to the controller.

15.13 Payload

Depending on the payload type, the following are stored.

1. VISCA command
 - Stores the packet of the VISCA command.
2. VISCA inquiry
 - Stores the packet of VISCA message.
3. VISCA reply
 - Stores the reply for the command or inquiry (Acknowledge message, completion message, or error message).
4. VISCA device setting command
 - Stores the packet of the VISCA device setting command.
5. Control command
 - The following are stored on the payload division of the control command.

Name	Value	Description
RESET	01h	Resets the sequence number to 0. The value that was set as the sequence number is ignored.
ERROR	0Fyyh	yy=01: Abnormality in the sequence number.
		yy=02: Abnormality in the message (message type)

6. Controlled reply
 - The following are stored on the payload division of the reply for the control command.

Message	Value	Description
Acknowledge	01h	Reply for RESET.

15.14 Delivery confirmation

VISCA over IP uses UDP as a communications protocol of the transport layer. Delivery of messages is not guaranteed for the UDP communication. Delivery confirmation and retransmission should be performed on the application.

When the controller sends a message to the peripheral device, wait until a reply for the message is received before sending the next message. You can confirm delivery of messages by managing the time-out waiting for a reply message sent.

If time out occurs on the controller, loss of one of the following message is considered:

- Command
- Acknowledge message
- Completion message for command
- Inquiry
- Reply message for the inquiry
- Error message
- Inquiry of the VISCA device setting command
- Reply message of the VISCA device setting command